

Internal gear pump
PGP Series 2X and 3X**RE 10231**

Edition: 07.2014

Replaces: 06.2005



HAD7065

- ▶ Fixed displacement
- ▶ Frame sizes 2 and 3
- ▶ Sizes 6.3 to 32
- ▶ Maximum pressure 350 bar
- ▶ Displacement 6.5 to 32.5 cm³

Features

- ▶ Low operating noise
- ▶ Low flow pulsation
- ▶ High efficiency even at low viscosity due to sealing gap compensation
- ▶ Long service life due to slide bearings and sealing gap compensation
- ▶ Suitable for a wide viscosity and speed range
- ▶ Excellent suction characteristics
- ▶ Can be combined with PGH and PGF internal gear pumps, vane pumps and axial piston pumps
- ▶ Use:
 - For drives with high operating pressure up to 10⁶ load cycles, for example trimming presses

Contents

Ordering code	2
Functional description	3
Technical data	4
Characteristic curves	6
Dimensions frame size 2	7
Dimensions frame size 3	8
Line connections	9
Multiple pump units	10
General project planning notes	11
Hydraulic project planning	11
Mechanical project planning	13
Maintenance schedule and operational safety	15
Accessories	15

Ordering code

01	02	03		04		05	06	07	08	09	10	11	12
PG	P		-		/		R			V			*

Type

01	Internal gear pump, fixed displacement, gap compensated	PG
----	---	-----------

Series

02	High-pressure pump, maximum pressure 350 bar	P
----	--	----------

Frame size (BG)

03	BG2	2
	BG3	3

Series

		BG2	BG3	
04	Series 20 to 29 (20 to 29: unchanged installation and port dimensions)	●	-	2X
	Series 30 to 39 (30 to 39: unchanged installation and port dimensions)	-	●	3X

Size

		NG	
05	BG2	6.3	006
		8.0	008
		11.0	011
		13.0	013
		16.0	016
	BG3	20.0	020
		25.0	025
		32.0	032

Direction of rotation

06	Viewed on drive shaft	clockwise	R
----	-----------------------	-----------	----------

Drive shaft

07	Parallel keyed shaft, ISO 3019-2 with through drive	E
	Splined shaft to SAE J744 with involute tooth system according to ANSI B92.1a	J

Line connections

08	Suction and pressure port according to SAE J518	07
	Square flange port according to DIN 3901 and DIN 3902, metric fastening thread	20

Seal material

09	FKM (fluor-caoutchouc)	V
----	------------------------	----------

Mounting flange

10	4-hole mounting flange according to ISO 3019-2 and VDMA 24560 part 1	E4
	2-hole mounting flange according to ISO 3019-1	U2

Optional

11	Cover for mounting of a PGP pump the next frame size down	K
----	---	----------

12	Further parameters in clear text	*
----	----------------------------------	----------

Type	Material number
PGP3-3X/025RE20VE4	R900086823

Not all of the variants according to the ordering code are possible! Please select the desired pump with the help of the selection table on pages 7 to 8 or after consultation with Bosch Rexroth!

Special options are available on request, e.g., integrated pressure-relief valves.

Functional description

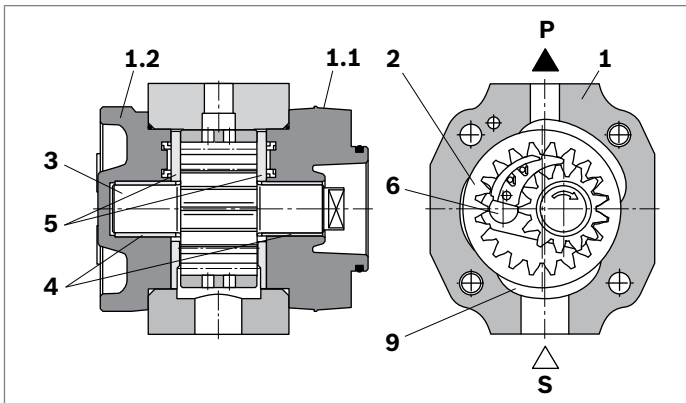

Design

PGP hydraulic pumps are leak-gap-compensated internal gear pumps with a fixed displacement. They consist basically of: housing (1), bearing cover (1.1), cover (1.2), ring gear (2), pinion shaft (3), slide bearings (4), axial discs (5) and stop pin (6) as well as the segment assembly (7) which is composed of a segment (7.1), segment carrier (7.2) and the sealing rolls (7.3).

Suction and displacement process

The hydrodynamically supported pinion shaft (3) drives the internally toothed ring gear (2) in the direction of rotation shown.

During rotation, the volume is increased in the suction area over an angle of approx. 180°. A negative pressure is generated and fluid flows into the chambers.

The sickle-shaped segment assembly (7) separates the suction chamber from the pressure chamber. Within the pressure chamber, the teeth of the pinion shaft (3) mesh with the tooth spaces of the ring gear (2). The fluid is then displaced through the pressure channel (P).

Axial compensation

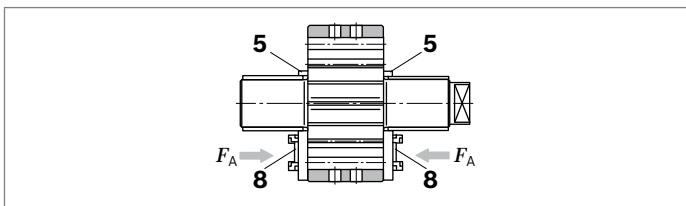

The axial compensation force F_A acts in the area of the pressure chamber and is generated by the pressure zone (8) in the axial discs (5). The axial, longitudinal gaps between rotating and fixed parts are therefore extremely small and ensure optimum axial sealing of the pressure chamber.

Radial compensation

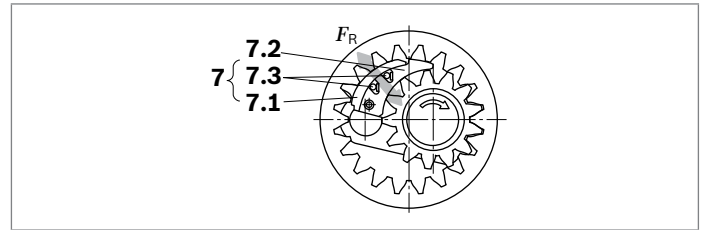

The radial compensation force F_R acts on the segment (7.1) and segment carrier (7.2).

The area ratios and the position of the sealing rolls (7.3) between the segment and segment carrier are designed to provide virtually gap-free sealing between the ring gear (2), the segment assembly (7) and the pinion shaft (3). Spring elements under the sealing rolls (7.3) ensure adequate contact pressure, even at very low pressures.

Hydrodynamic and hydrostatic bearing

The forces acting on the pinion shaft (3) are absorbed by hydrodynamically lubricated radial slide bearings (4) while those acting on the ring gear (2) are absorbed by the hydrostatic bearing (9).

Splines

Involute splining was selected for the gear. Their long length of contact results in a low flow and pressure pulsation; these low pulsation rates contribute greatly to the low-noise operation.

Used materials

Housing (1), bearing cover (1.1), cover (1.2) and axial discs (5): Steel-aluminum compound material
Ring gear (2), pinion shaft (3) and stop pin (6): Steel
Slide bearing (4): Copper-tin with steel back
Segment (7.1) and segment carrier (7.2): Brass alloy
Sealing rolls (7.3): Plastic

▼ Symbol

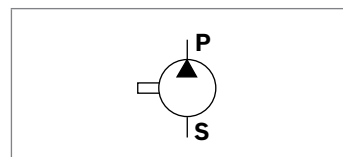

Technical data

Frame size		BG	2	2	2	2	2
Size		NG	6.3	8	11	13	16
Displacement, geometric	V_g	cm ³	6.5	8.2	11	13.3	16
Input speed	n_{min}	min ⁻¹	600	600	600	600	600
	n_{max}	min ⁻¹	1800	1800	1800	1800	1800
Operating pressure, absolute							
Inlet	p	bar	0.8 to 2	0.8 to 2	0.8 to 2	0.8 to 2	0.8 to 2
Outlet	continuous	p_N	bar	250	250	250	250
	intermittend ¹⁾	p_{max}	bar	315 ²⁾ / 350 ³⁾	315 ²⁾ / 350 ³⁾	315 ²⁾ / 350 ³⁾	315 ²⁾ / 350 ³⁾
Flow (at $n = 1450 \text{ min}^{-1}$, $p = 10 \text{ bar}$, $v = 30 \text{ mm}^2/\text{s}$)	q_v	l/min	9.4	11.9	16	19.3	23.2
Power consumption							
Minimum required drive power (at $p \approx 1 \text{ bar}$)	p_{zu}	kW	0.75	0.75	0.75	0.75	0.75
Weight	m	kg	3.0	3.1	3.3	3.5	3.6
Shaft loading	Radial and axial forces (e.g., belt pulley) only after consultation						
Type of mounting	Flange mounting						

Frame size		BG	3	3	3
Size		NG	20	25	32
Displacement, geometric	V_g	cm ³	20.6	25.4	32.5
Input speed	n_{min}	min ⁻¹	600	600	600
	n_{max}	min ⁻¹	1800	1800	1800
Operating pressure, absolute					
Inlet	p	bar	0.8 to 2	0.8 to 2	0.8 to 2
Outlet	continuous	p_N	bar	250	250
	intermittend ¹⁾	p_{max}	bar	315 ²⁾ / 350 ³⁾	315 ²⁾ / 350 ³⁾
Flow (at $n = 1450 \text{ min}^{-1}$, $p = 10 \text{ bar}$, $v = 30 \text{ mm}^2/\text{s}$)	q_v	l/min	29.9	36.8	47.1
Power consumption					
Minimum required drive power (at $p \approx 1 \text{ bar}$)	p_{zu}	kW	1.1	1.5	1.5
Weight	m	kg	4.3	5.1	5.5
Shaft loading	Radial and axial forces (e.g., belt pulley) only after consultation				
Type of mounting	Flange mounting				

1) Attention! This value must not be exceeded even by a pressure peak.

2) Maximum 6 s, up to 15 % of duty cycle
 maximum 10×10^6 load cycles

3) Maximum 1 s, up to 10 % of duty cycle
 maximum 1×10^6 load cycles

Hydraulic fluid	
Permissible hydraulic fluid ⁴⁾	HL mineral oil according to DIN 51524 Part 1/HLP, mineral oil according to DIN 51524 Part 2 HEES fluids according to DIN ISO 15380 HEPR fluids according to DIN ISO 15380
Operating temperature range	-20 to +80 °C
Ambient temperature range	-20 to +60 °C
Viscosity range	10 to 300 mm/s ²
Permissible starting viscosity	2000 mm/s ²
Maximum permissible degree of contamination of the hydraulic fluid	Class 20/18/15 ⁵⁾
Cleanliness level according to ISO 4406 (c)	

Note

- ▶ Please contact us if the unit is to be used outside the specified values.
- ▶ Observe our specifications according to data sheet 90220.

4) Other hydraulic fluids on request

5) Cleanliness levels specified for the components must be maintained in the hydraulic systems. Effective filtration prevents malfunctions and simultaneously extends the service life of the components.

Characteristic curves

Frame size 2

▼ Flow

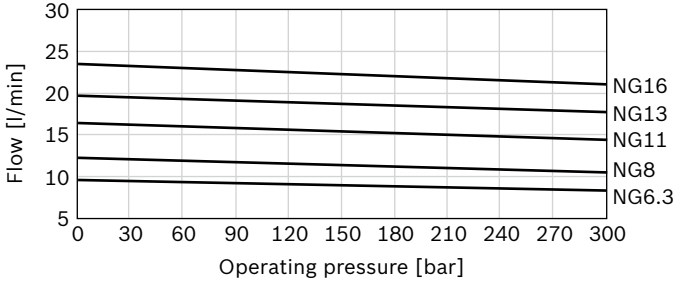

▼ Efficiency

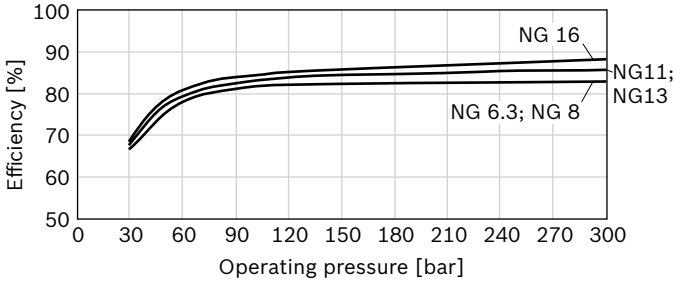

▼ Drive power

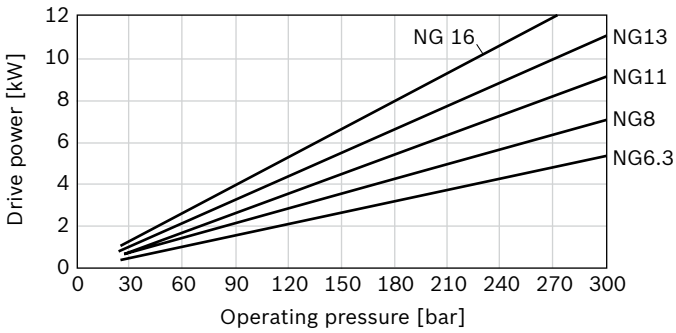

▼ Sound pressure level

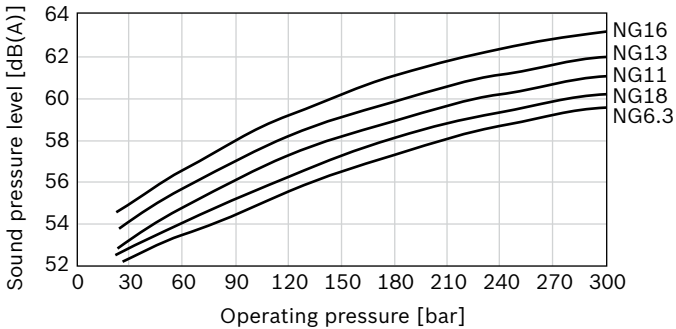

Frame size 3

▼ Flow

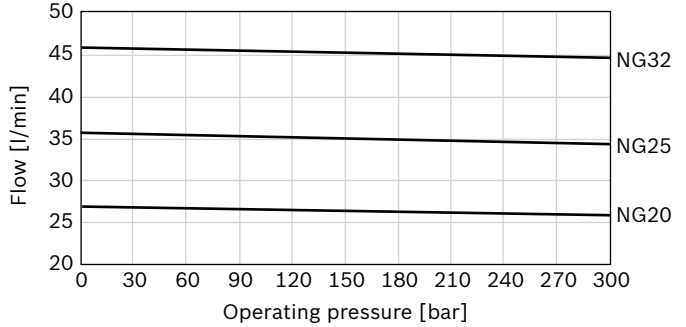

▼ Efficiency

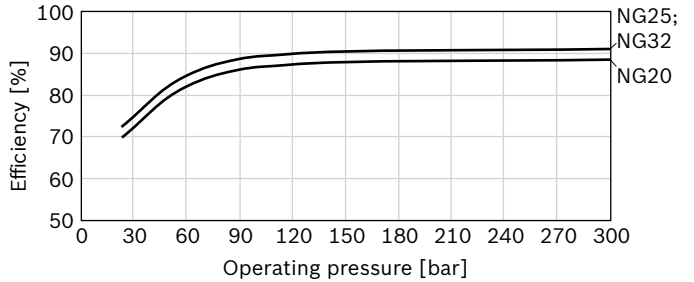

▼ Drive power

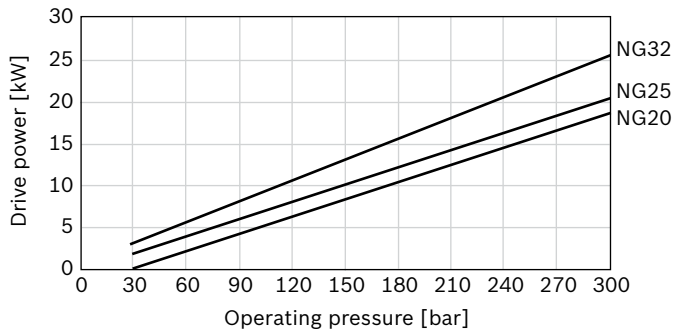

▼ Sound pressure level

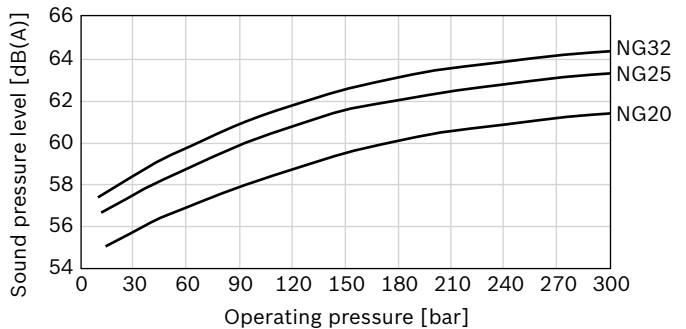

Note

Characteristics measured at $n = 1450$ rpm; $v = 46$ mm²/s; $\theta = 40$ °C

Sound pressure level measured in acoustic room according to DIN 45635, Sheet 26; Distance: microphone – pump = 1 m

Dimensions frame size 2

Parallel keyed shaft, DIN 6885, with through drive

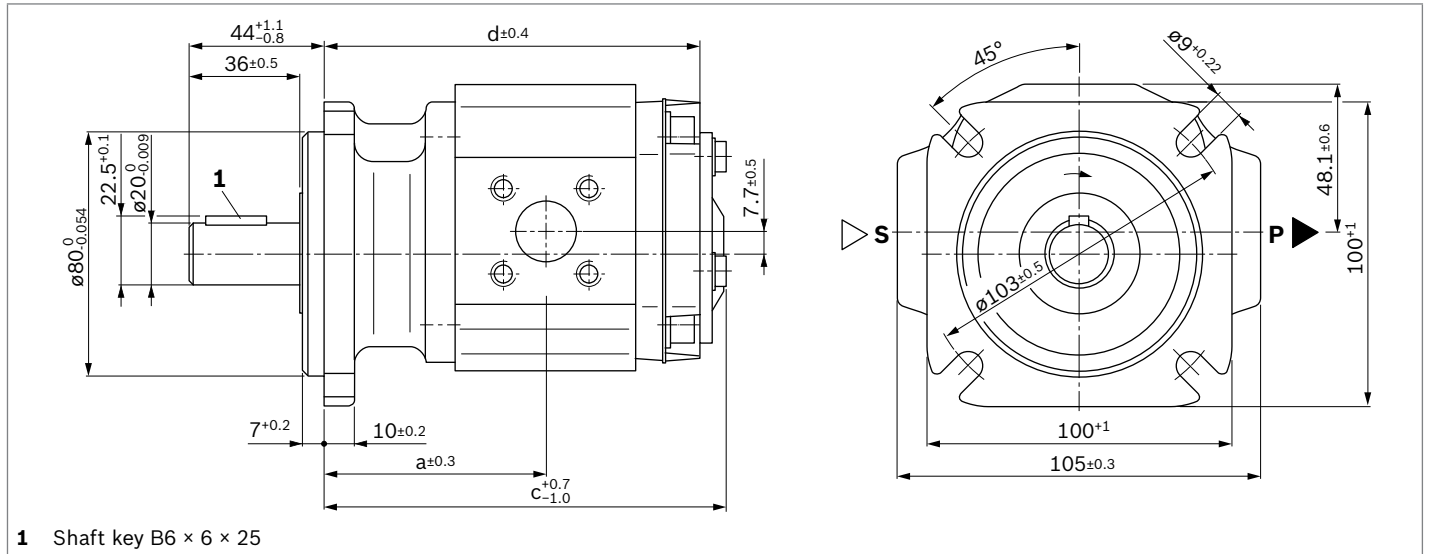

Type	Material numbers	a	c	d	S ³⁾	P ³⁾
PGP2-2X/ 006 R E 20VE4	R900932129	63	115.2	104.1	Ø20, TK Ø40 ¹⁾	Ø6, TK Ø35 ²⁾
008 R E 20VE4	R900081891	64.8	118.7	107.6	Ø20, TK Ø40 ¹⁾	Ø8, TK Ø35 ²⁾
011 R E 20VE4	R900932114	67.5	124.2	113.1	Ø20, TK Ø40 ¹⁾	Ø12, TK Ø35 ²⁾
013 R E 20VE4	R900086819	70	129.2	118.1	Ø20, TK Ø40 ¹⁾	Ø12, TK Ø35 ²⁾
016 R E 20VE4	R900932177	72.5	134.2	123.1	Ø20, TK Ø40 ¹⁾	Ø12, TK Ø35 ²⁾

Splined shaft, with through drive

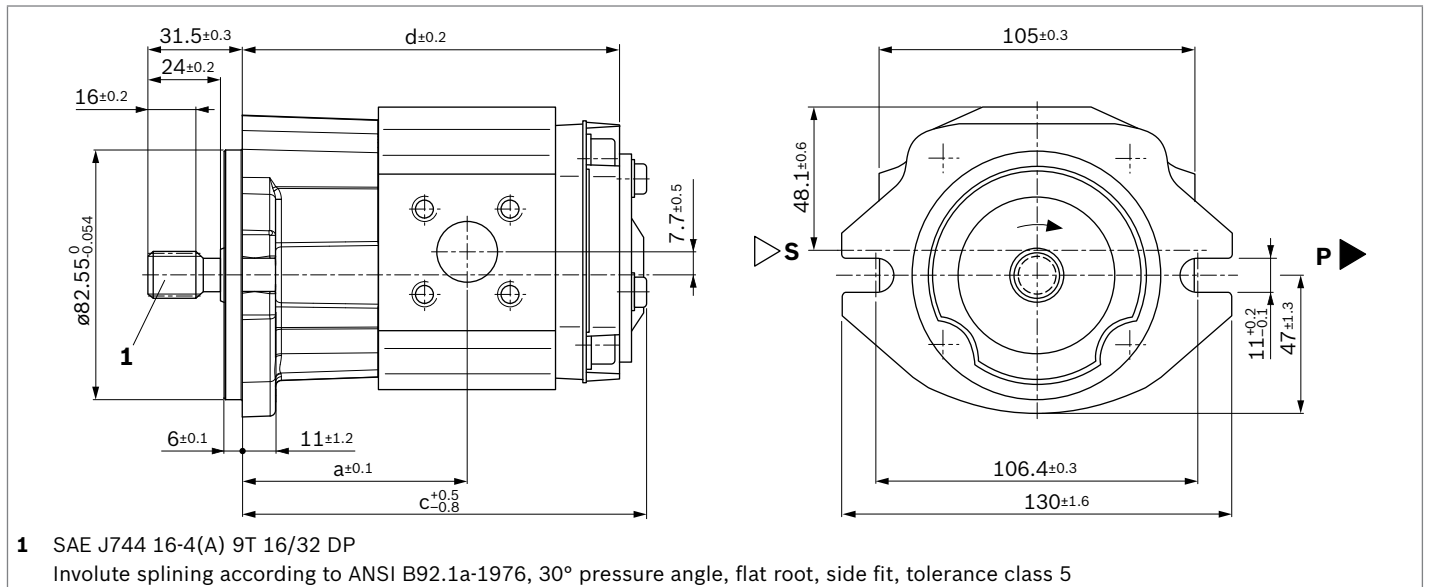

Type	Material numbers	a	c	d	S ³⁾	P ³⁾
PGP2-2X/ 006 R J 20VU2	R900984018	65	117.2	106.1	Ø20, TK Ø40 ¹⁾	Ø6, TK Ø35 ²⁾
008 R J 20VU2	R900984019	66.8	120.7	109.6	Ø20, TK Ø40 ¹⁾	Ø8, TK Ø35 ²⁾
011 R J 20VU2	R900984020	69.5	126.2	115.1	Ø20, TK Ø40 ¹⁾	Ø12, TK Ø35 ²⁾
013 R J 20VU2	R900984021	72	131.2	120.1	Ø20, TK Ø40 ¹⁾	Ø12, TK Ø35 ²⁾
016 R J 20VU2	R900984022	74.5	136.2	125.1	Ø20, TK Ø40 ¹⁾	Ø12, TK Ø35 ²⁾

TK = Pitch circle

1) Fastening thread M6; 10 deep

2) Fastening thread M6; 12 deep

3) Line connections see page 9

Dimensions frame size 3

Parallel keyed shaft, DIN 6885, with through drive

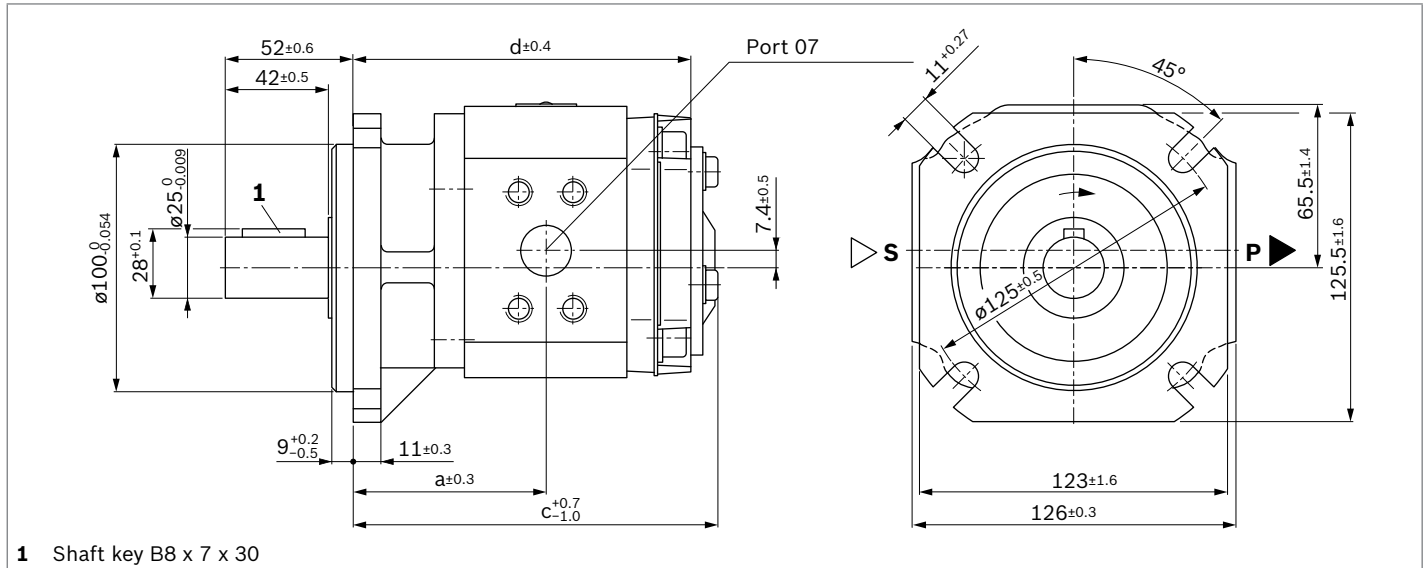

Type	Material numbers	a	c	d	S ⁴⁾	P ⁴⁾
PGP3-3X/ 020 R E 20VE4	R900932178	71	137.1	126	Ø26, TK Ø55 ¹⁾	Ø12, TK Ø35 ²⁾
025 R E 20VE4	R900086823	74	143.1	132	Ø26, TK Ø55 ¹⁾	Ø12, TK Ø35 ²⁾
032 R E 07VE4	R900086824	78.5	152.1	141	SAE 1 1/4 in S ³⁾	SAE 3/4 in S ³⁾

Splined shaft, with through drive

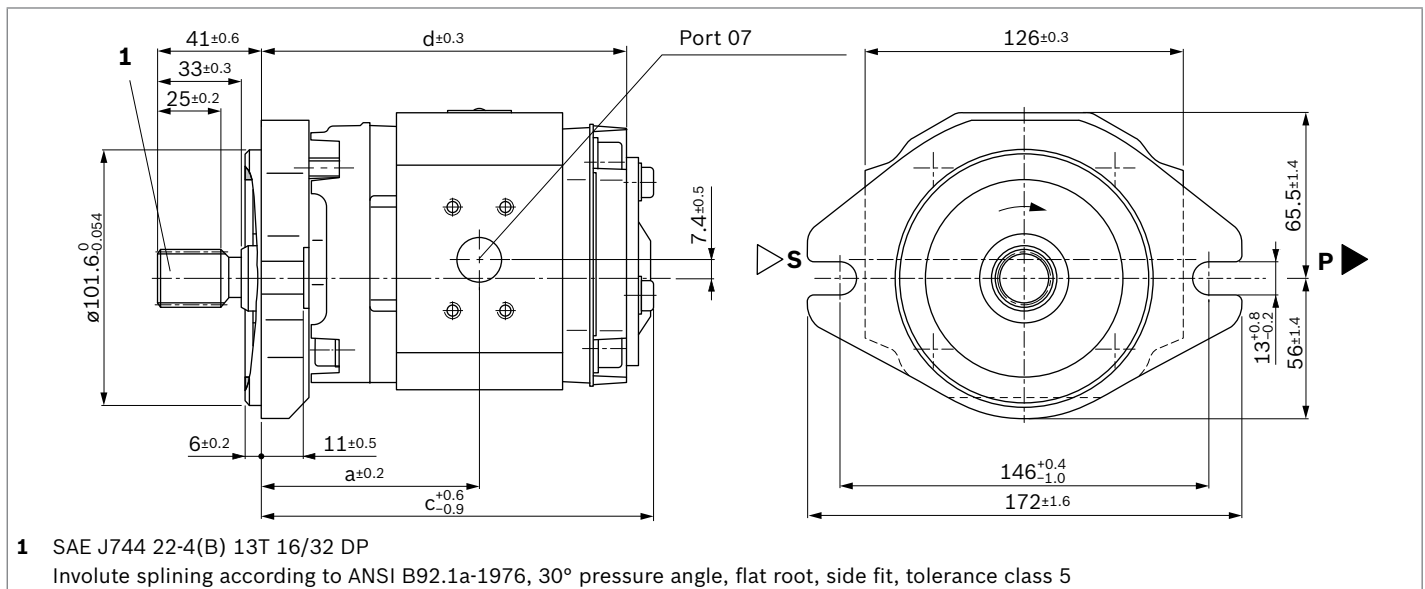

Type	Material numbers	a	c	d	S ⁴⁾	P ⁴⁾
PGP3-3X/ 020 R J 20VU2	R900984025	79.5	145.6	134.5	Ø26, TK Ø55 ¹⁾	Ø12, TK Ø35 ²⁾
025 R J 20VU2	R900984027	82.5	151.6	140.5	Ø26, TK Ø55 ¹⁾	Ø12, TK Ø35 ²⁾
032 R J 07VU2	R900984028	92	160.6	149.5	SAE 1 1/4 in S ³⁾	SAE 3/4 in S ³⁾

TK = Pitch circle

- 1) Fastening thread M8; 12 deep
- 2) Fastening thread M6; 12 deep

- 3) Standard pressure series
- 4) Line connections see page 9

Line connections

▼ Port type 20 square flange port

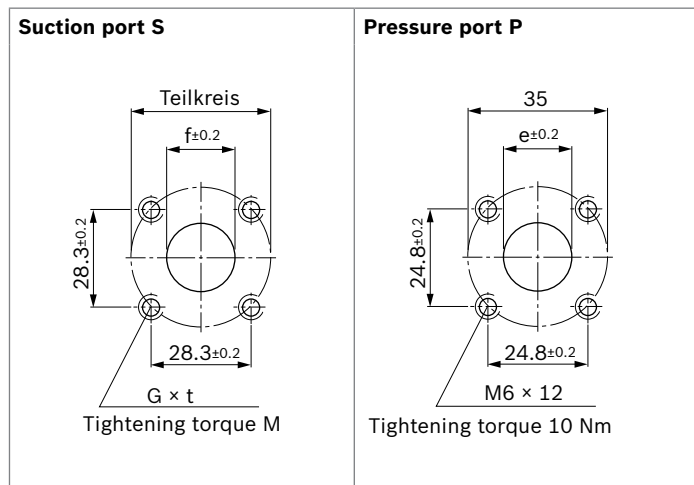

▼ Port type 07, SAE flange port, for BG3 NG032

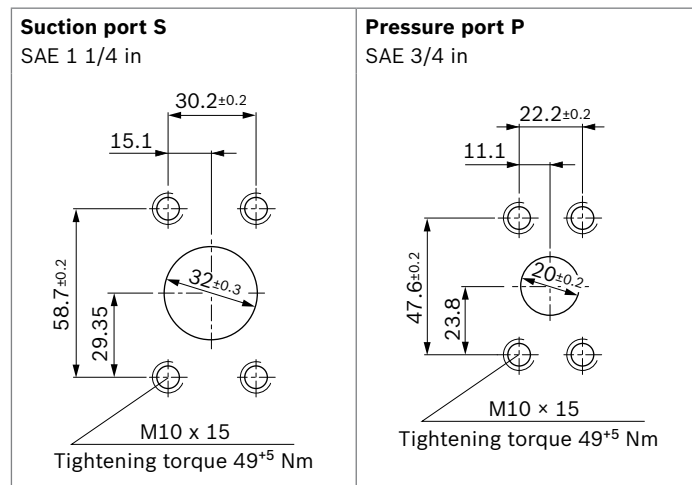

BG	NG	Pitch circle	G	t	e	f	M [Nm]
2	006	40	M6	10	6	20	10
	008	40	M6	10	8	20	10
	011	40	M6	10	12	20	10
	013	40	M6	10	12	20	10
	016	40	M6	10	12	20	10
3	020	55	M8	12	12	26	25
	025	55	M8	12	12	26	25

10 **PGP Series 2X and 3X** | Internal gear pump
Multiple pump units

Multiple pump units

Ordering code

01	02		03		04		05	06	07	08		09	10
P2	PGP	/		+	PGF	/		R			+		

Type

01	2-fold	P2
----	--------	-----------

02	Series of the first pump	PGP
----	--------------------------	------------

03	Size of the first pump ¹⁾	
----	--------------------------------------	--

04	Series of the second pump	PGF
----	---------------------------	------------

05	Size of the second pump ²⁾	
----	---------------------------------------	--

Direction of rotation

06	Viewed on drive shaft	clockwise	R
----	-----------------------	-----------	----------

Drive shaft of the first pump

07	Parallel keyed shaft, ISO 3019-2 with through drive	E
	Splined shaft to SAE J744 with involute tooth system according to ANSI B92.1a	J

Wire connections for the first pump

08	Suction and pressure port according to SAE J518	07
	Square flange port according to DIN 3901 and DIN 3902, metric fastening thread	20

Wire connections for the second pump

09	Suction and pressure port according to SAE J518	07
	Square flange port according to DIN 3901 and DIN 3902, metric fastening thread	20

Mounting flange of the first pump

10	4-hole mounting flange according to ISO 3019-2 and VDMA 24560 Part 1	E4
	2-hole mounting flange according to ISO 3019-1	U2

1) PGP see page 2

2) PGF see data sheet 10213

General project planning notes

Intended use

Internal gear pumps are intended for the assembly of hydraulic drive systems in machine and system construction.

Technical data

The system or machine manufacturer must ensure compliance with the permissible technical data and operating conditions. The pump itself does not contain a device to prevent operation outside the permissible data. It is possible to operate the pump outside of the permissible technical data to a certain extent; the express written consent from Bosch Rexroth is, however, required.

All specified technical performance features are median values and apply with the specified general conditions. In case of modifications to the general conditions (e.g., viscosity), the technical data may change as well. Scatter corresponding to the relevant state of technology is possible.

Hydraulic project planning

Air bleeding option for commissioning

For Rexroth PGP.-2/3X internal gear pumps, a manual or switchable air bleeding option for the initial commissioning or any recommissioning after maintenance and repair work is to be provided. The air bleeding point is to be set in the pressure line before the first valve or check valve. Air bleeding may be performed with a maximum counter pressure of 0.2 bar.

Examples of air bleeding circuits

▼ Switchable air bleeding

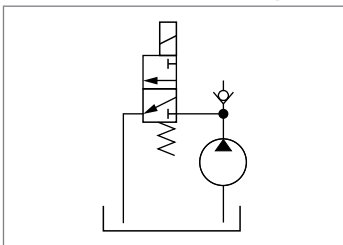

▼ Manually actuated air bleeding

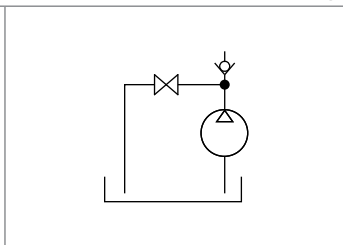

Suction line

The line cross sections are to be dimensioned for the specified flows such that an ideal suction speed of 0.6 to 1.2 m/s is achieved on average. The suction speed should not exceed a maximum value of 2 m/s.

The suction cross sections at the pump itself are designed for the maximum flow and therefore serve only as reference. In case of continuous operation at rotational speeds lower than the permissible maximum speed, the suction tube diameter is also to be dimensioned smaller than the suction port of the pump depending on the actual suction speed.

Overall, the suction line is to be designed so that the permissible inlet operating pressure is maintained. Bends and a combination of suction pipes from several pumps are to be avoided. If the use of a suction filter is unavoidable, it must be ensured on the system side that the lowest permissible inlet operating pressure is not exceeded even if the filter is contaminated.

Ensure the air tightness of the transitions and the pressure resistance of the suction hose with respect to the external air pressure.

The immersion depth of the suction pipe should be selected as large as possible (at least 100 mm at the lowest fluid level). Depending on the internal reservoir pressure, the viscosity of the operating medium and the flow conditions within the reservoir, no vortex may form even at maximum flow. There is otherwise a risk of air being drawn in. Return fluid and case drain fluid must not be immediately be drawn in again.

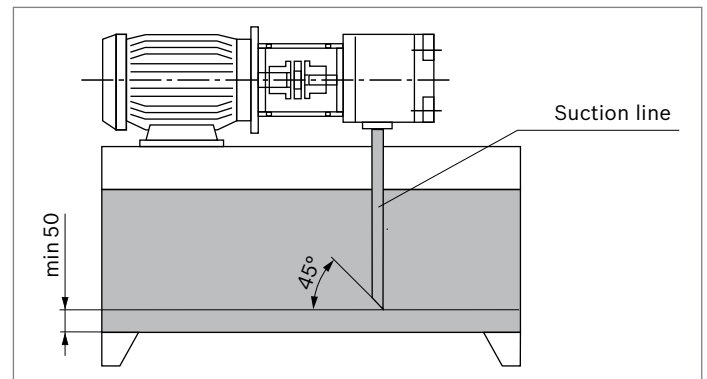

Pressure line

Sufficient burst resistance of the pipes, hoses and connecting elements must be ensured for pressure lines. The cross sections should be based on the maximum flow in order to avoid additional excessive loading of the pump due to back-pressure. Here, you must also take into account the pipe losses over the entire pressure line length and other line resistances (e.g., bends, pressure filters).

Pressure safeguarding

The PGP internal gear pump does not include any devices for adherence to the maximum operating pressure. The setting and safeguarding of the permissible operating pressure must be ensured on the system side.

The pressure-relief valves necessary for this purpose are to be designed with consideration given to the maximum flow and the rate of pressure increase that will occur such that the permissible intermittent operating pressure is not exceeded.

Pressure holding function

In the variable-speed drive, the pump can also be temporarily operated in the pressure holding function below the specified minimum rotational speed. The holding time and the rotational speed necessary for this purpose are a function of the operating viscosity and the pressure level. For the design, please contact Bosch Rexroth's technical sales department.

In the deactivated state (rotational speed = 0), a leakage flow flows through the pump back into the reservoir, depending on the load pressure. If this is to be prevented, a check valve is to be used.

When using a check valve, please observe the note on the air bleeding option for commissioning, page 11.

Mechanical project planning

Mounting

On the machine side, the screws are to be accessible in such a way that the required tightening torque can be applied. The screw tightening torque is oriented towards the operating conditions and elements involved in the screw connection and is to be specified by the manufacturer during project planning of the power unit, the machine, or the system.

Reservoir

When designing the reservoir or selecting a suitable standard reservoir, the following requirements are to be observed:

- ▶ Select the largest possible reservoir volume, depending on the continuous or average flow, which is needed in order to allow separation of air bubbles by means of sufficient dwell time of the medium in the reservoir. The air separation ability of the used hydraulic fluid is also of importance here.
- ▶ Provide settling zones for the hydraulic fluid in the reservoir in order to allow for air separation.
- ▶ Provide guiding plates in order to allow contamination at the reservoir bottom to be deposited outside the pump suction area.
- ▶ Generously dimension the reservoir surfaces depending on the heat output to be dissipated via the reservoir walls.

Required power unit functions

At a minimum, the hydraulic power units should be equipped with the following features:

- ▶ Reservoirs that are designed so that the internal pressure corresponds to the ambient pressure should be equipped with ventilation filters for pressure compensation purposes.
- ▶ The hydraulic fluid should only be filled using filling nozzles that eliminate the possibility of filling with unfiltered fluid.
- ▶ The ingress of contamination or moisture must be avoided. If used in highly contaminated environments, the reservoir must, for this purpose, be precharged by means of air pressure. If cleaning of the reservoir exterior is planned or anticipated during the period of use, reservoir bushings for pipes, lines, or hoses are to be selected so that a secure seal is ensured against external pressurization with a water jet.

Place of installation and ambient conditions

With places of installation at a geodetic height of more than 1000 m, the pump is to be arranged in or below the reservoir or the reservoir is to be precharged by means of compressed air in order to ensure the permissible minimum inlet pressure. A short suction line with large cross section is to be selected; bends should not be used.

When installing the pump more than 10 m below the reservoir, the reduction of the inlet pressure to the maximum permissible value must be ensured by means of additional measures.

If operating the pump in salt-containing or corrosive environments or if there is a possibility of pressurization with strongly abrasive substances, it must be ensured on the system side that the shaft seal ring and the sealing area of the shaft do not make direct contact with the environment.

Drive

Electric motor + pump support + coupling + pump

- ▶ No radial or axial forces permissible on the pump drive shaft!
- ▶ Motor and pump must be exactly aligned!
- ▶ Always use a coupling that is suitable for compensating for shaft offsets!

Installation positions

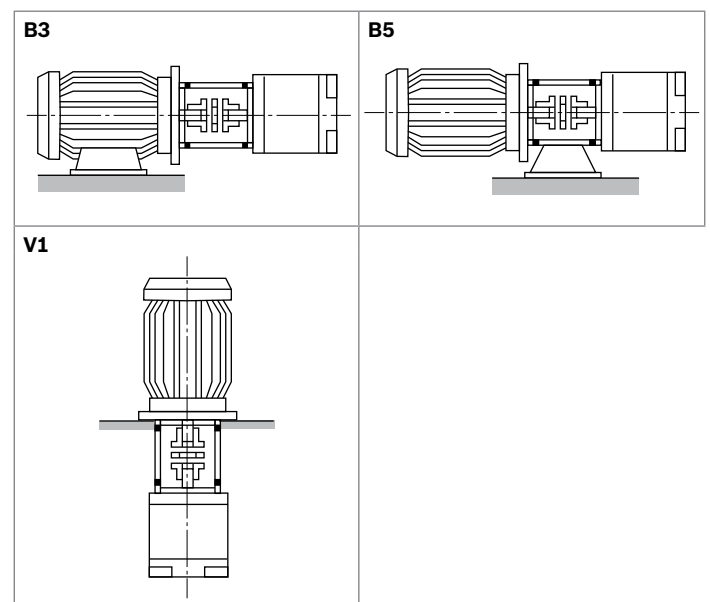

Pump combinations

- ▶ With pump combinations, make sure that the operating data approved for the pump type concerned can be complied with in every step.
- ▶ Combined pumps must all have the same direction of rotation.
- ▶ The pump with the highest torque, variable pumps or pumps with intermittent pressure loading should be specified as the first step in the pump combination.
- ▶ The engineer must verify the maximum through-drive torque for every application. This also applies for existing (coded) pump combinations.
- ▶ The sum of all input torques in a pump combination may not exceed the permissible input torque of the first pump.

▼ Maximum input torque [Nm]

Shaft	E	J
PGP2	140	90
PGP3	230	230

▼ Formula for input torque

$$T = \frac{\Delta p \times V \times 0.0159}{\eta_{\text{hydr.-mech.}}} \quad [\text{Nm}]$$

Key

- T = Input torque [Nm]
- Δp = Operating pressure [bar]
- V = Displacement [cm³]
- η = Hydraulic mechanical efficiency

▼ Maximum output torque [Nm]

Shaft	E	J
PGP2	70	70
PGP3	140	140

- ▶ Common suction is not possible.
- ▶ For reasons of strength and stability, we recommend using ISO 4-hole mounting flanges according to VDMA "E4" for combinations of three or more pumps.
- ▶ Before operating pump combinations with different media, please consult Bosch Rexroth.
- ▶ PGF combinations are installed without combination parts and are not sealed against each other.

Selection

- ▶ The front pump must have shaft version **E** or **J**.
- ▶ The middle pump must have shaft version **L**.
- ▶ The rear pump must have shaft version **N**.
- ▶ If a pump of the next smaller frame size is to be mounted, the designation of the first pump must end with "**K**" (e.g., PGP3 + PGF2 ⇒ front pump: PGP3-3X/032RE07VE4K)

Dimensions

- ▶ The dimensions of the ports are the same as for single pumps (see page 7 to 8).
- ▶ The total length of the pump combination is calculated by adding up dimensions "d" of the single pumps (see pages 7 to 8).
- ▶ With the combination of PGP2 and PGF1, the installation length of the PGP2 (dimension d) increases by 4.5 mm.
With the combination of PGP3 and PGF2, the installation length of the PGP3 (dimension d) increases by 2 mm.
With the combination of PGP3 and PGF1, the installation length of the PGP3 (dimension d) increases by 12.5 mm.

Maintenance schedule and operational safety

For safe operation and a long service life of the pump, a maintenance schedule must be prepared for the power unit, the machine, or the system. The maintenance schedule must ensure that the specified or permissible operating conditions of the pump are complied with over the entire period of use.

In particular, compliance with the following operating parameters is to be ensured:

- ▶ The required oil cleanliness
- ▶ The operating temperature range
- ▶ The filling level of the operating medium

Furthermore, the pump and the system are to be checked for changes to the following parameters on a regular basis:

- ▶ Vibrations
- ▶ Noise
- ▶ Temperature difference between pump – fluid in the reservoir
- ▶ Foaming in the reservoir
- ▶ Leak-proofness

Changes to these parameters indicate component wear (e.g., diesel engine, coupling, pump, etc.). The reason is to be determined and remedied immediately.

In order to achieve high operational safety of the pump in the machine or system, we recommend checking the aforementioned parameters continuously and automatically and the automatic shut-down in case of changes exceeding the usual fluctuations in the specified operating range.

Plastic components of drive couplings should be replaced regularly, though after no more than 5 years. The corresponding manufacturer's specifications are paramount.

For preventive maintenance of the pump, we recommend having the seals replaced after an operating period of no more than 5 years by an authorized Bosch Rexroth service company.

Accessories

Pump safety block

For limiting the operating pressure and for the pump circulation at zero pressure, we recommend our pump safety blocks of type DBA... according to data sheet 25890.

Automatic air bleeding during commissioning is, however, not possible via DBA blocks. In this case, we recommend separate, manual air bleeding.

Bosch Rexroth AG

Mobile Applications
Zum Eisengießer 1
97816 Lohr am Main, Germany
Tel. +49 9352 18-0
info.ma@boschrexroth.de
www.boschrexroth.com

© Alle Rechte bei Bosch Rexroth AG, auch für den Fall von Schutzrechtsanmeldungen. Jede Verfügungsbefugnis, wie Kopier- und Weitergaberecht, bei uns. Die angegebenen Daten dienen allein der Produktbeschreibung. Eine Aussage über eine bestimmte Beschaffenheit oder eine Eignung für einen bestimmten Einsatzzweck kann aus unseren Angaben nicht abgeleitet werden. Die Angaben entbinden den Verwender nicht von eigenen Beurteilungen und Prüfungen. Es ist zu beachten, dass unsere Produkte einem natürlichen Verschleiß- und Alterungsprozess unterliegen.