

Internal gear pump PGH

Fixed displacement

Series 2X

RE 10223

Edition: 04.2013

Replaces: 03.2005

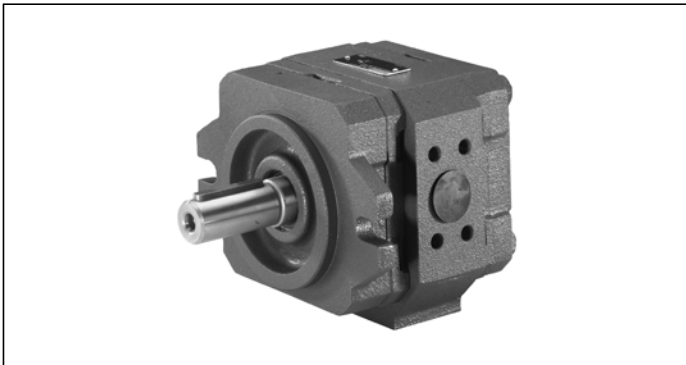

- ▶ Frame sizes 2 and 3
- ▶ Size 5 to 16
- ▶ Maximum pressure 350 bar
- ▶ Displacement 5.2 to 16.0 cm³

Features

- ▶ Fixed displacement
- ▶ Low operating noise
- ▶ Low flow pulsation
- ▶ High efficiency even at low rotational speed and viscosity due to sealing gap compensation
- ▶ Suitable for a wide viscosity and speed range
- ▶ All frame sizes and sizes can be optionally combined with each other
- ▶ Can be combined with internal gear pumps, radial piston pumps and external gear pumps

Contents

Ordering code	2
Functional description	3
Technical data	4
Characteristic median values for frame sizes 2 and 3	5
Dimensions frame size 2	6
Dimensions frame size 3	7
Multiple pump units	9
SAE connection flanges	12
Pump safety block	12
Engineering notes	13
Installation instructions	14
Commissioning instructions	15

Ordering code

01	02	03	04	05	06	07	08	09	10	11
PG	H		2X	/			07		U2	

Type

01	Internal gear pump, fixed displacement, gap compensated	PG
----	---	-----------

Series

02	High pressure pump, maximum pressure 350 bar	H
----	--	----------

Frame sizes BG

03	BG2	2
	BG3	3

Unit series

04	Unit series 20 to 29 (20 to 29: unchanged installation and connection dimensions)	2X
----	---	-----------

Sizes

		NG	
05	BG2	5	005
		6	006
		8	008
	BG3	11	011
		13	013
		16	016

Directions of rotation

06	Viewed on drive shaft	clockwise	R
		counter-clockwise	L

Drive shafts

07	Parallel keyed shaft, DIN 6885		E
	Splined shaft to SAE J744 with involute spline to ANSI B92.1a	16-4 (A) 9T 16/32DP	R
		19-4 11T 16/32DP	S

Line ports

08	Suction and pressure port to SAE, pressure port standard pressure series	07
----	--	-----------

Seals

09	FKM (fluor-caoutchouc)	V
	FKM (fluor-caoutchouc), shaft seal in NBR (nitrile-caoutchouc) ¹⁾	W

Mounting flange

10	SAE 2-hole	U2
----	------------	-----------

11	Further parameters in clear text	
----	----------------------------------	--

Ordering example

PGH3-2X/016RE07VU2

Material number

R900951305

Not all of the variants according to the ordering code are possible! Please select the desired pump with the help of the selection table (page 6 to 8) or after consultation with Bosch Rexroth.

¹⁾ For HFC-fluids

Functional description

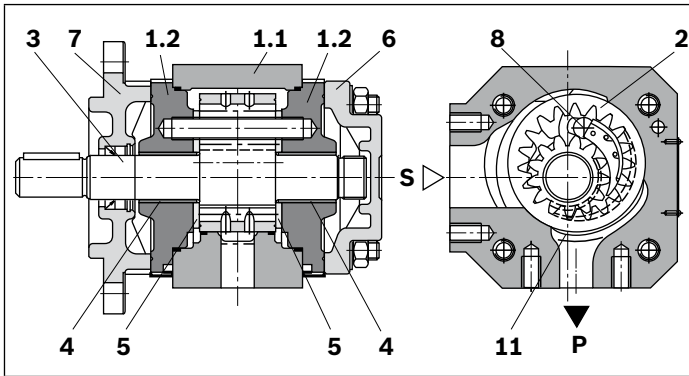

Assembly

PGF hydraulic pumps are leak gap-compensated internal gear pumps with a fixed displacement. They consist basically of housing (1.1), bearing cover (1.2), ring gear (2), pinion shaft (3), slide bearings (4), axial discs (5), end cover (6), mounting flange (7) and stop pin (8), as well as the segment assembly (9), which is composed of a segment (9.1), segment carrier (9.2) and the sealing rolls (9.3).

Suction and displacement process

The hydro dynamically supported pinion shaft (3) drives the internally toothed ring gear (2) in the direction of rotation shown.

During rotation, the volume is increased in the suction area over an angle of approx. 90°. A negative pressure is generated and fluid flows into the chambers.

The sickle-shaped segment assembly (9) separates the suction chamber from the pressure chamber. Within the pressure chamber, the teeth of the pinion shaft (3) mesh with the tooth spaces of the ring gear (2). The fluid is then displaced through the pressure channel (P).

Axial compensation

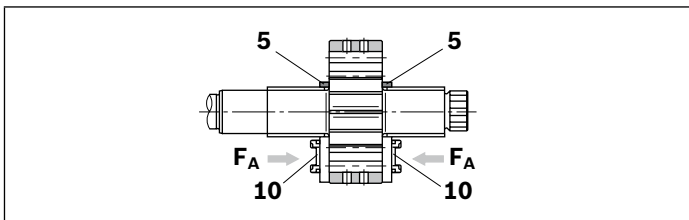

The axial compensation force F_A acts in the area of the pressure chamber and is generated by the pressure zone (10) in the axial discs (5).

The axial, longitudinal gaps between rotating and fixed parts are therefore extremely small and ensure optimum axial sealing of the pressure chamber.

Radial compensation

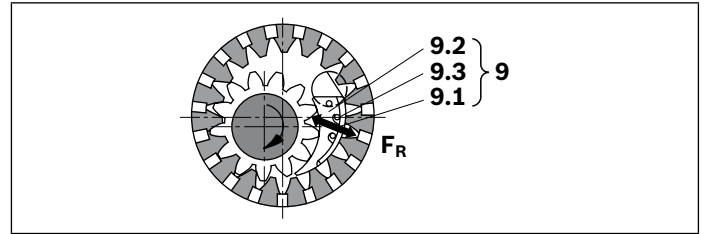

The radial compensation force F_R acts on the segment (9.1) and segment carrier (9.2).

Depending on the operating pressure the two segment assemblies (9.1) and (9.2) are pressed against the pinion shaft-head diameter (3) and the ring gear (2). The area ratios and the position of the sealing rolls (9.3) between the segment and segment carrier are designed to provide virtually gap-free sealing between the ring gear (2), the segment assembly (9) and the pinion shaft (3). Spring elements under the sealing rolls (9.3) ensure adequate contact pressure, even at very low pressures.

Hydrodynamic and hydrostatic bearing

The forces acting on the pinion shaft (3) are absorbed by hydro dynamically lubricated radial slide bearings (4) while those acting on the ring gear (2) are absorbed by the hydrostatic bearing (11).

Splines

Involute splining was selected for the splines. Their long length of contact results in a low flow and pressure pulsation; these low pulsation rates greatly contribute to the low-noise operation.

▼ Symbol

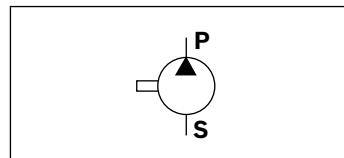

Technical data

Frame size		BG	2	2	2	3	3	3
Size		NG	5	6	8	11	13	16
Displacement, geometric	V_g	cm ³	5.24	6.5	8.2	11.0	13.3	16.0
Drive speed	n_{min}	rpm	600	600	600	600	600	600
	n_{max}	rpm	3000	3000	3000	3000	3000	3000
Operating pressure, absolute								
Inlet	p	bar	0.8 to 2 (short-term at start 0.6 bar)					
Outlet	continuous							
	Standard fluid	p_n	bar	315	315	315	315	315
	Special fluid ¹⁾	p_n	bar	210	210	210	210	210
	intermittend ²⁾							
	Standard fluid	p_{max}	bar	350	350	350	350	350
Special fluid ¹⁾	p_{max}	bar	230	230	230	230	230	
Flow (at $n = 1450$ rpm, $p = 10$ bar, $\nu = 46$ mm ² /s)	q_v	l/min	7.5	9.3	11.8	15.8	19.1	23.0
weight	m	kg	4.3	4.4	4.6	4.8	5	5.3
Shaft loading	Radial and axial forces (e. g., belt pulley) only after consultation							
Type of mounting	Flange mounting							
Hydraulic fluid								
Standard fluid	HLP mineral oil according to DIN 51524 Part 2							
Special fluid	<ul style="list-style-type: none"> ▶ Environmentally acceptable fluids HEES according to DIN ISO 15380 ▶ Fire resistant anhydrous fluids HFD-U according to VDMA 24317 ▶ Hydrous polymer-solutions HFC according to DIN EN ISO 12922³⁾ ▶ Observe our application instructions and application requirements in the data sheets 90220 (HLP), 90221 (HEES) and 90222 (HFD-U). ▶ Other fluids on request! 							
Temperature range	°C	Standard fluid	-10 to +80, for other temperatures please consult us!					
		Special fluid	-10 to +50, for other temperatures please consult us!					
Ambient temperature range	°C	-20 to +60						
Viscosity range	mm/s ²	10 to 300; permissible starting viscosity 2000						
Maximum permissible degree of contamination of the hydraulic fluid.	Class 20/18/15 ⁴⁾							
Cleanliness level according to ISO 4406 (c)								

Note

Please contact us if the unit is to be used outside the specified values!

- 1) For special fluids observe restrictions of the technical data!
- 2) Maximum 10 s, at most 50 % of the duty cycle
- 3) Execution of seals W
- 4) Cleanliness levels specified for the components must be maintained in the hydraulic systems. Effective filtration prevents malfunctions and simultaneously extends the service life of the components.
 For the selection of the filters see data sheets 50070, 50076, 50081, 50086, 50087 and 50088.

Characteristic median values for frame sizes 2 and 3

▼ **Flow**

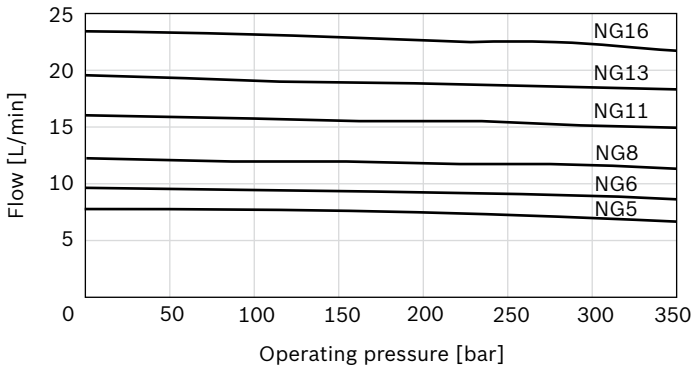

▼ **Efficiency**

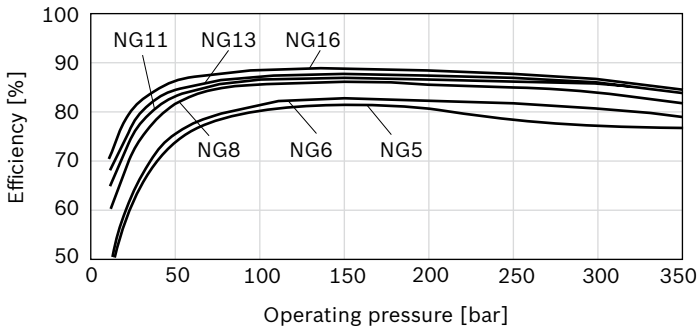

▼ **Drive power**

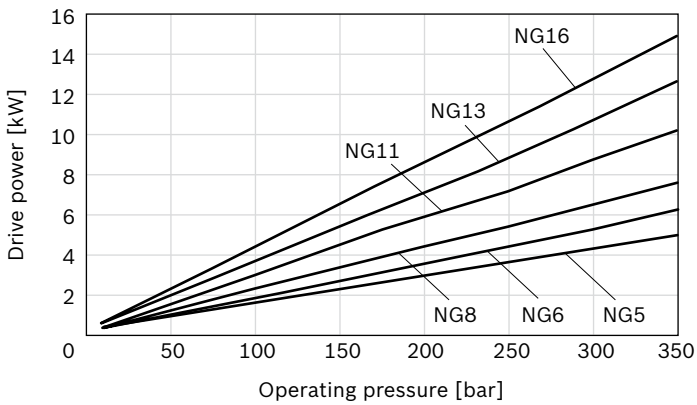

▼ **Sound pressure level**

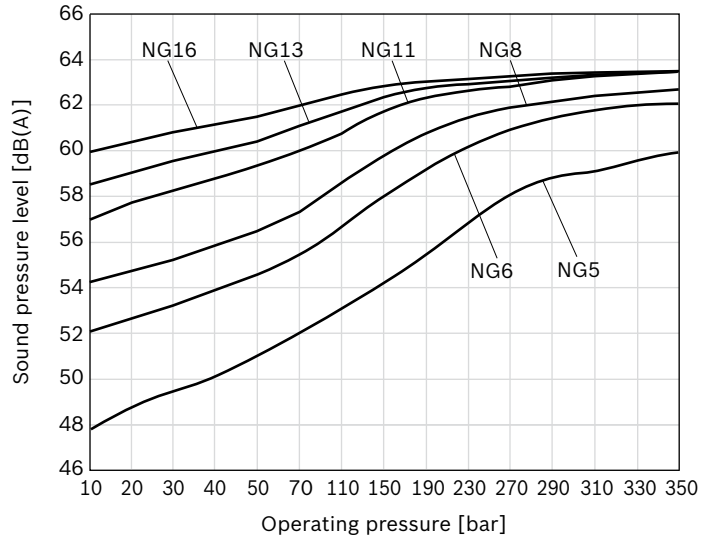

Note

- ▶ Characteristics measured at $n = 1450$ rpm;
 $\nu = 41 \text{ mm}^2/\text{s}$; $\theta = 50 \text{ }^\circ\text{C}$
- ▶ Sound pressure level measured in acoustic room according to DIN 45635, page 26;
 distance sound sensor – pump = 1 m

Dimensions frame size 2

With parallel keyed shaft or splined shaft SAE J744 and SAE-mounting flange 82-2

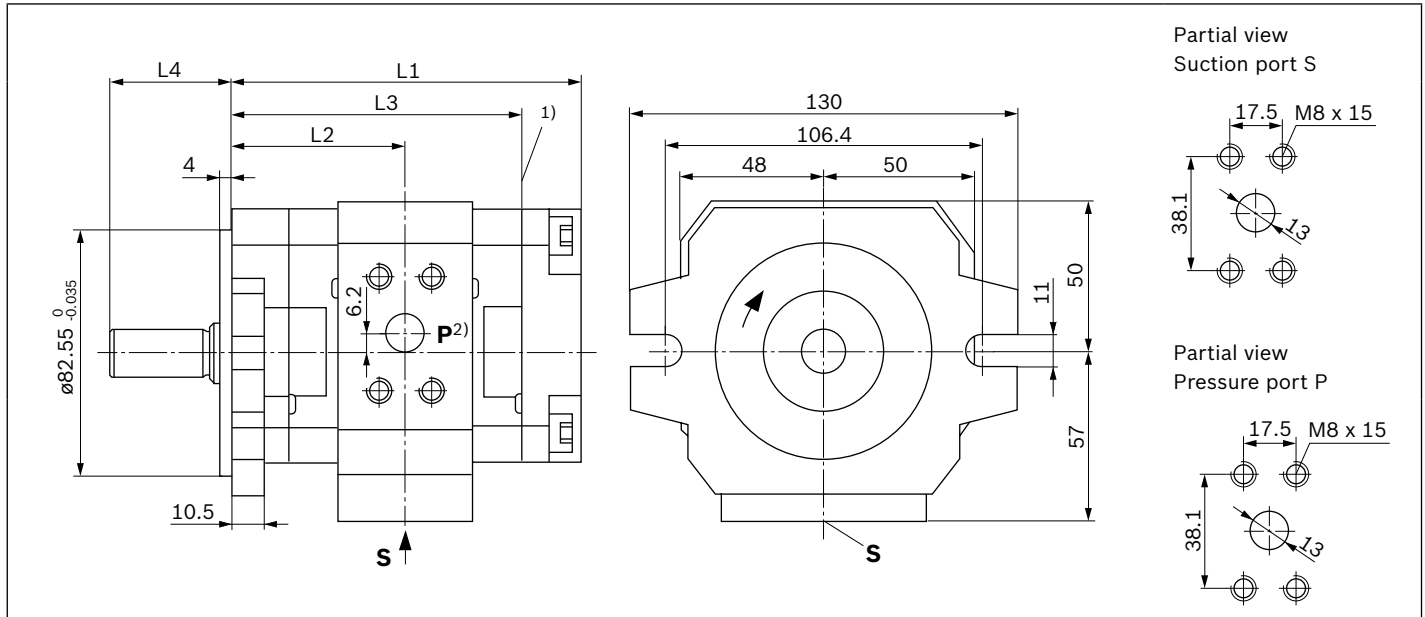

Type	Material numbers	L1	L2	L3	L4	Suction port S ⁴⁾	Pressure port P ⁴⁾	
PGH2-2X/005	R ³⁾ E 07VU2	R900968999	110	54.2	89.5	41	1/2 in; 5000 psi	1/2 in; 5000 psi
	L	R900703725						
	R ³⁾ R 07VU2	R900972378				31.5		
	L	R900703727						
006	R ³⁾ E 07VU2	R900951301	112.5	55.5	92	41	1/2 in; 5000 psi	1/2 in; 5000 psi
	L	R900961547						
	R ³⁾ R 07VU2	R900961549				31.5		
	L	R900961550						
008	R ³⁾ E 07VU2	R900951302	116	57.3	95.5	41	1/2 in; 5000 psi	1/2 in; 5000 psi
	L	R900961548						
	R ³⁾ R 07VU2	R900961551				31.5		
	L	R900961552						

▼ Parallel keyed shaft DIN 6885

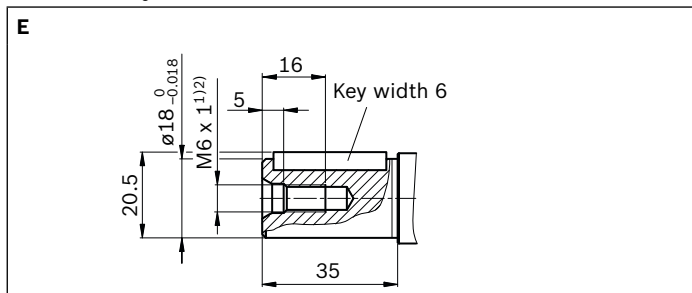

▼ Splined shaft SAE J744

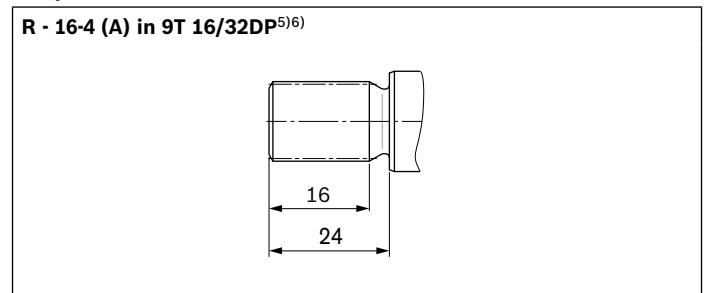

- 1) At multiple pump units the combination part starts here
- 2) Shown are pumps in clockwise rotation, pumps in counter clockwise rotation have the pressure port on the opposite side!
- 3) Preferably available

- 4) Standard pressure range
- 5) In multiple pump units suitable as middle and rear pump
- 6) Involute spline to ANSI B92.1a, 30° pressure angle, flat root, side fit, tolerance class 5

Dimensions frame size 3

With parallel keyed shaft and SAE-mounting flange 101-2

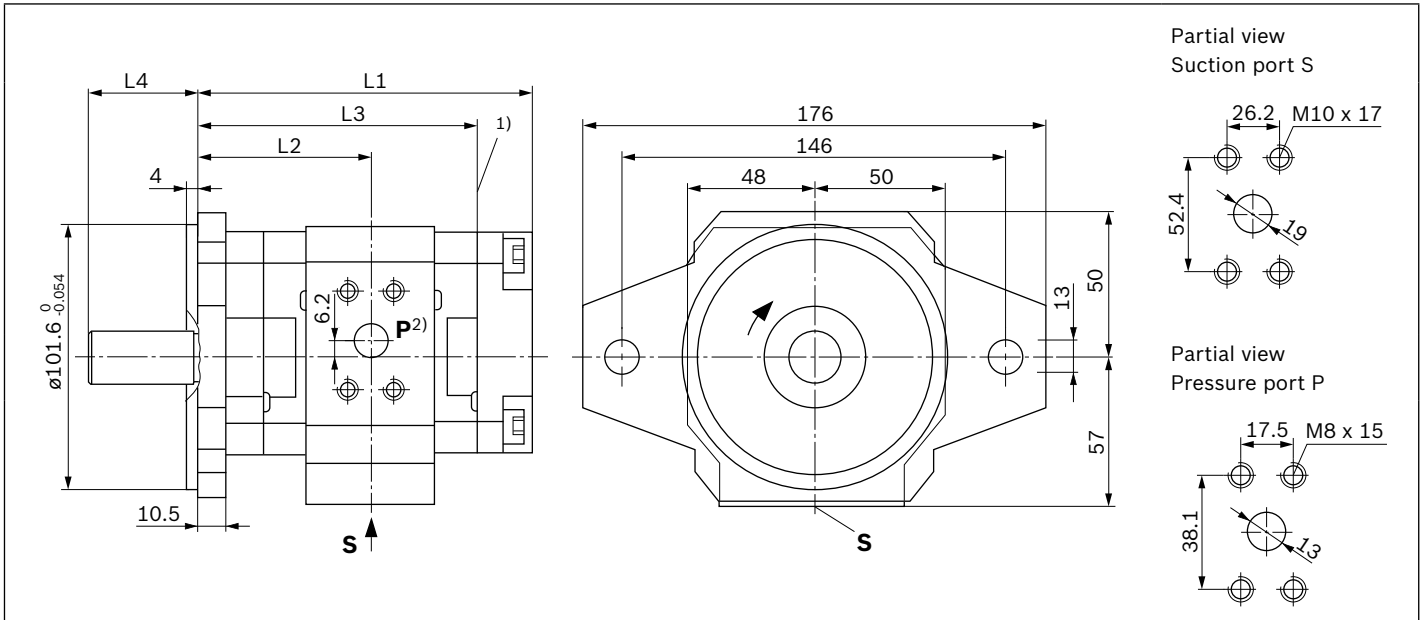

Type		Material numbers	L1	L2	L3	L4	Suction port S ⁴⁾	Pressure port P ⁴⁾
PGH3-2X/ 011	R ³⁾ E 07VU2	R900951303	128	66.5	107.5	41	1 in; 3000 psi	1/2 in; 5000 psi
	L	R900961553						
013	R ³⁾ E 07VU2	R900951304	133	69	112.5	41	1 in; 3000 psi	1/2 in; 5000 psi
	L	R900961554						
016	R ³⁾ E 07VU2	R900951305	138	71.5	117.5	41	1 in; 3000 psi	1/2 in; 5000 psi
	L	R900961555						

▼ Parallel keyed shaft DIN 6885

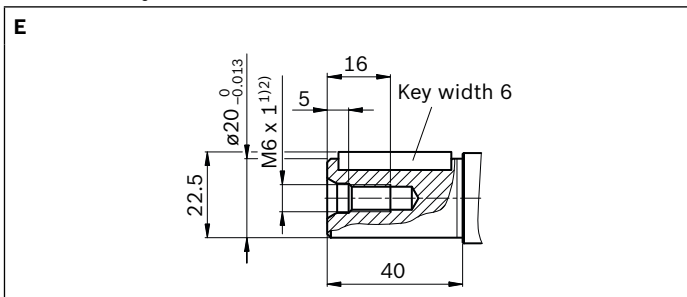

- 1) At multiple pump units the combination part starts here
- 2) Shown are pumps in clockwise rotation, pumps in counter clockwise rotation have the pressure port on the opposite side!
- 3) Preferably available
- 4) Standard pressure range

With splined shaft SAE J744 and SAE-mounting flange 82-2

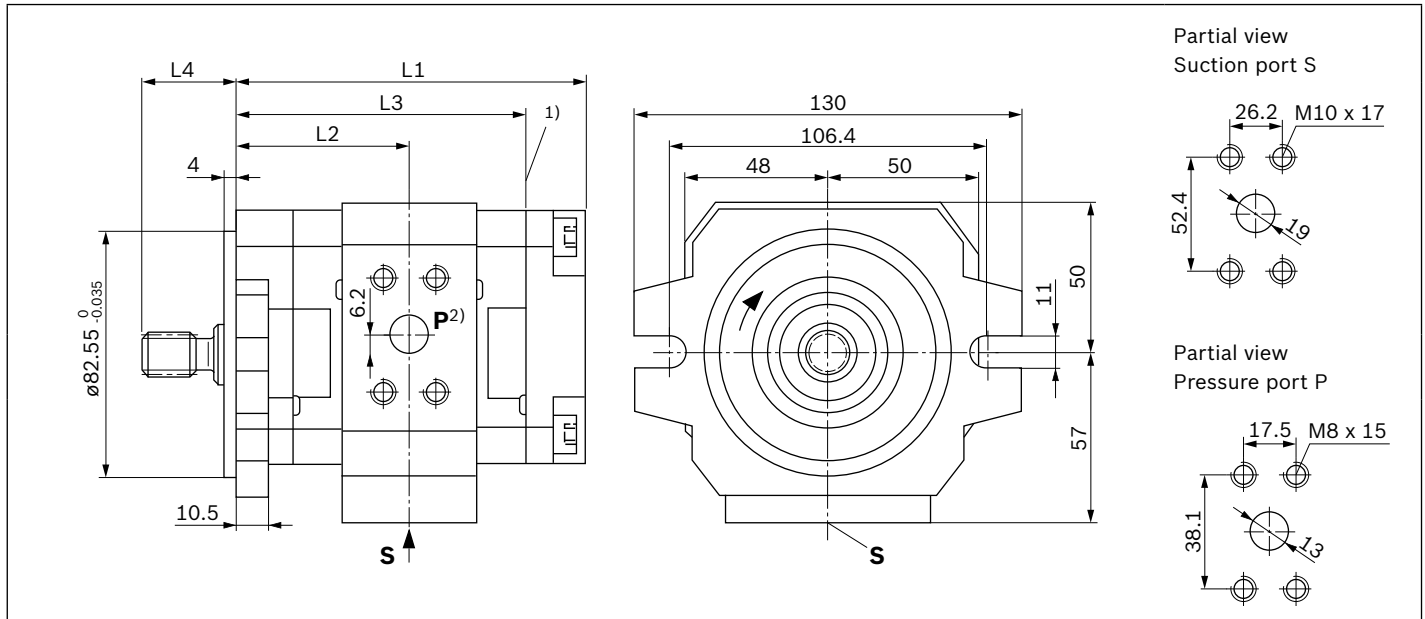

Type	Material numbers	L1	L2	L3	L4	Suction port S ⁴⁾	Pressure port P ⁴⁾
PGH3-2X/011 R ³⁾ R 07VU2	R900961556	121.5	60	101	31.5	1 in; 3000 psi	1/2 in; 5000 psi
	R900961559						
	R901267181						
013 R ³⁾ R 07VU2	R900961557	126.5	62.5	106	31.5	1 in; 3000 psi	1/2 in; 5000 psi
	R900961560						
	R901281697						
016 R ³⁾ R 07VU2	R900961558	131.5	65	111	31.5	1 in; 3000 psi	1/2 in; 5000 psi
	R900961561						
	R901281698						

▼ **Splined shaft SAE J744**

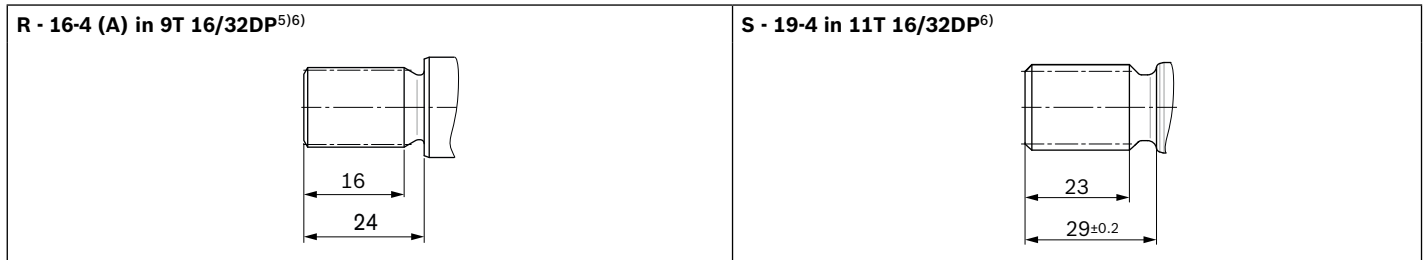

- 1) At multiple pump units the combination part starts here
- 2) Shown are pumps in clockwise rotation, pumps in counter clockwise rotation have the pressure port on the opposite side!
- 3) Preferably available
- 4) Standard pressure range
- 5) In multiple pump units suitable as middle and rear pump
- 6) Involute spline according to ANSI B92.1a, 30° pressure angle, flat root, side fit, tolerance class 5

Multiple pump units

All internal gear pumps type PGH are combinable, every pump has a through drive connection. The combination options and the material numbers for the necessary combination parts can be taken from the following table.

Rear pump	Front pump	
	PGH2-2X	PGH3-2X
PGH2-2X/...R...U2	R900886137	R900886137
PGH3-2X/...R...U2	R900886137	R900886137
PGP2-2X/...J...U2	R900886137	R900886137
PGF2-2X/...J...U2	R900886137	R900886137
AZPF...RR...B	R900886137	R900886137
PR4-1X...WA	R901015657	R901015657

10 **PGH Series 2X** | Internal gear pump
Multiple pump units

Ordering code

01	02	03	04	05	06	07	08	09	10	11	12	13	14	15
		/	+	/	+	/				+		+		

Type

01	2-fold	P2
	3-fold	P3

02	Series of the first pump ¹⁾	
----	--	--

03	Size of the first pump ¹⁾	
----	--------------------------------------	--

04	Series of the second pump ¹⁾	
----	---	--

05	Size of the second pump ¹⁾	
----	---------------------------------------	--

06	Series of the third pump ¹⁾	
----	--	--

07	Size of the third pump ¹⁾	
----	--------------------------------------	--

Direction of rotation

08	Viewed on drive shaft	clockwise	R
		counter-clockwise	L

Drive shaft of the first pump

09	Parallel keyed shaft, DIN 6885		E
	Splined shaft to SAE J744 with involute tooth system to ANSI B92.1a	16-4 (A) 9T 16/32DP	R
		19-4 11T 16/32DP	S

Line port of the first pump

10	Suction and pressure port to SAE, pressure port standard pressure series	07
----	--	-----------

Drive shaft of the second pump²⁾

11	Parallel keyed shaft, DIN 6885		A
	Splined shaft to SAE J744 with involute tooth system to ANSI B92.1a	16-4 (A) 9T 16/32DP	J
			R

Line port of the second pump

12	Suction and pressure port to SAE, pressure port standard pressure series	07
----	--	-----------

Drive shaft of the third pump²⁾

13	Parallel keyed shaft, DIN 6885		A
	Splined shaft to SAE J744 with involute tooth system to ANSI B92.1a	16-4 (A) 9T 16/32DP	J
			R

Line port of the third pump

14	Suction and pressure port to SAE, pressure port standard pressure series	07
----	--	-----------

Mounting flange of the first pump

15	SAE 2-hole ²⁾	U2
----	--------------------------	-----------

1) Detailed information see ordering code page 2

2) See table page 9

Dimensions

The dimensional drawings show the first pump and the combination part.¹⁾

PGH2/PGH3

PGH2 with combination part for PGH2, PGH3, PGF2, PGP2, AZPF

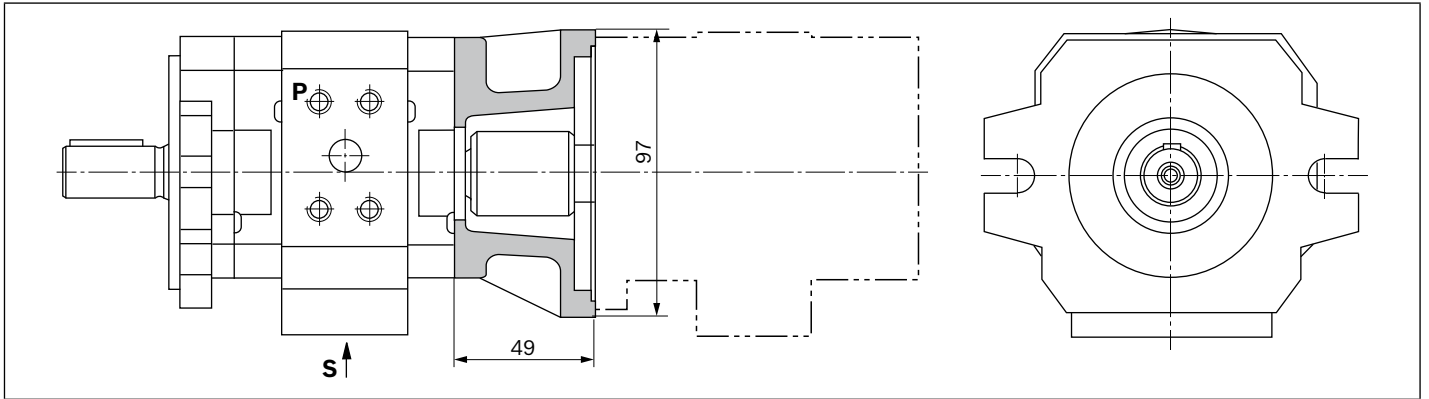

PGH2/PGH3 + R4-Mini

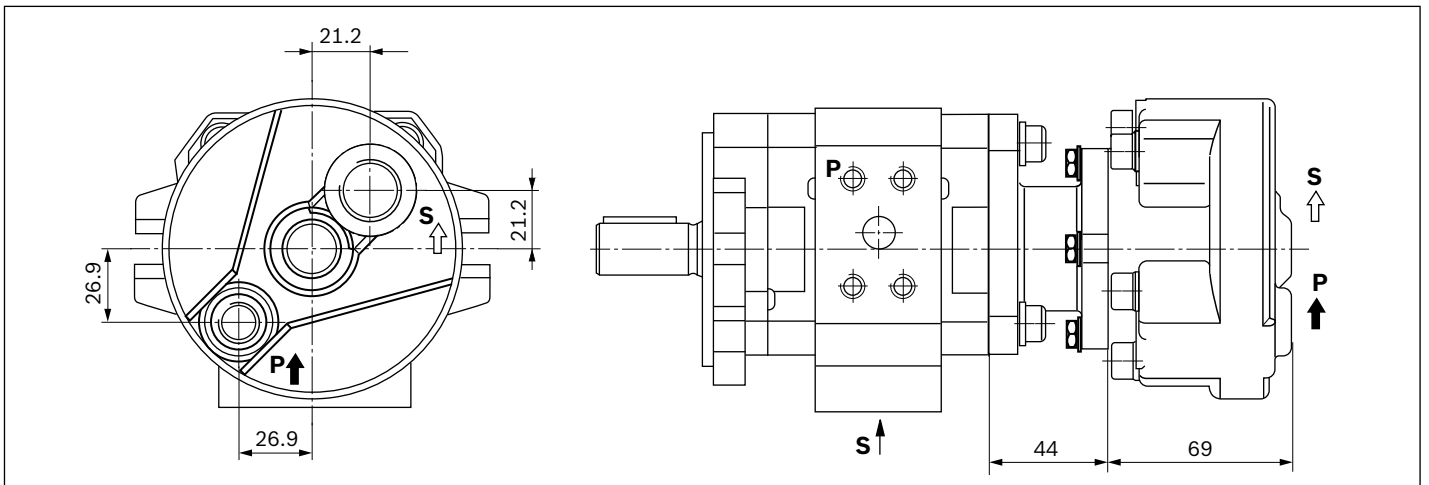

¹⁾ Dimensions of the single pumps see page 6 to 8 or the relevant data sheets of the rear pump.

SAE connection flanges

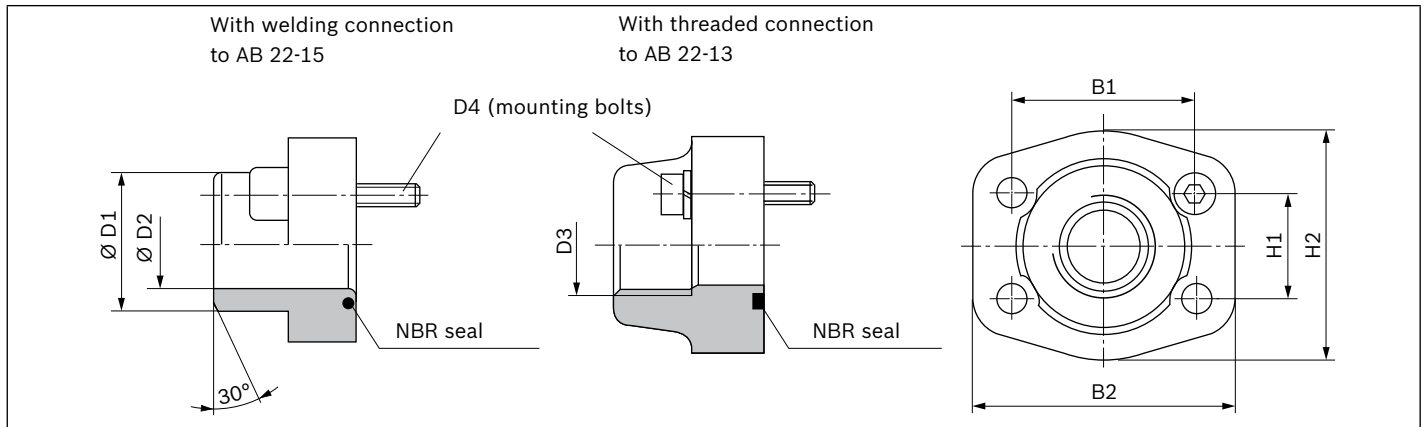

PGH		Flange NG, pressure	Material number ¹⁾ for flange with		Dimensioning							
Suction flange	Pressure flange		Welding port	Threaded connection ²⁾	B1	B2	H1	H2	D1	D2	D3	D4
PGH2/005/ 006/008	PGH2/005/ 006/008 PGH3/011/ 013/016	1/2 in 5000 psi	R900026298	R900024200	38.1	54	17.5	46	20	14	G1/2	M8 x 30
PGH3/011/013/016,	-	1 in 3000 psi	R900012937	R900014154	52.4	70	26.2	59	35	27	G1	M10 x 35

Pump safety block

For limitation of the operating pressure or (and) for solenoid-actuated relief of operating pressure we recommend our pump-pressure-safety-block to data sheets 25880 and 25891.

1) The material numbers comprise the flange, the O-ring (NBR) and the mounting bolts.

2) Pipe thread "G" according to DIN EN ISO 228/1

Engineering notes

Extensive notes and suggestions can be found in the Hydraulic Trainer, volume 3 "Project planning recommendations and design of hydraulic systems".

When using internal gear pumps, provide an additional manual, switchable or automatic air bleeding option. The air bleeding point for manual air bleeding must be provided in the pressure line upstream of the first valve or check valve to ensure air bleeding can be performed depressurized.

Technical data

All mentioned technical data are dependent on manufacturing tolerances and are applicable for certain boundary conditions.

Note that certain deviations are therefore possible and that technical data may vary when boundary conditions (e. g., viscosity) change.

Characteristic curves

When dimensioning the drive motor, observe the maximum possible application data on the basis of the characteristics shown on the page 5.

Sound pressure level

The shown values for the sound pressure level on page 5 were measured in dependence on DIN 45635, sheet 26. This means that only the noise emitted by the pump is shown. Ambient influences (installation site, piping etc.) were not taken into account.

These values always refer to only one pump.

With internal gear pumps, the excitation of valves, pipelines, machine parts, etc. is very low due to the low flow pulsation (approx. 2 to 3 %).

Nevertheless, under unfavorable conditions, the sound pressure level at the installation site of the power unit can be 5 to 10 dB(A) higher than the values of the pump itself.

Multiple pump units

- ▶ The same general technical data apply as for the single pumps (see page 4).
- ▶ Combined pumps must all have the same direction of rotation.
- ▶ The pump with the largest input drive torque should be taken as the first pump.
- ▶ The engineer must verify the maximum through-drive torque for each application. This also applies for existing (coded) multiple pumps.
- ▶ The sum of all input torques in a multiple pump unit may not exceed the permissible input torque of the first pump.
- ▶ Common suction is not possible.
- ▶ Before operating pump combinations with different hydraulic fluids, please contact Bosch Rexroth.
- ▶ The middle and the rear pump must feature the drive shaft execution "R" (stronger spline).
- ▶ The drive torque of a pump stage is calculated as follows:

$$T = \frac{\Delta p \cdot V \cdot 0.0159}{\eta_{\text{hydr-mech}}}$$

Key

T	Torque T [Nm]
Δp	Operating pressure [bar]
V	Displacement [cm ³]
η	Hydraulic mechanical efficiency

▼ Maximum permissible torques [Nm]

Type	Drive torque			Output torque
	Parallel shaft E	Splined shaft R	Splined shaft S	
PGH2	100	80	155	75
PGH3	110	80	155	75

Installation instructions

Fluid tank

- ▶ Adjust the usable capacity of the tank to the operating conditions.
- ▶ The permissible fluid temperature must not be exceeded; provide a cooler if necessary.

Lines and ports

- ▶ Remove protective plug from the pump.
- ▶ Select the clear width of pipes according to the ports (suction speed 1 to 1.5 m/s).
- ▶ Inlet pressure see page 4
- ▶ Thoroughly clean pipelines and fittings prior to installing.

Proposal for piping layout

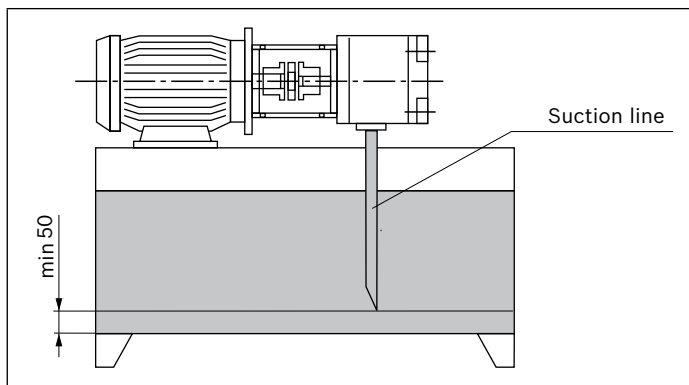

- ▶ Under no circumstances may returning fluid be drawn directly into the suction port again, i. e., select the largest possible distance between suction line and return line.
- ▶ The suction line and return tank line must always be clearly below the oil level.
- ▶ Ensure suction-tight installation of the pipelines.

Filter

If possible, use return-line filter or pressure filters.
(Only use suction filters in combination with a low pressure switch/ contamination indicator).

Hydraulic fluid

- ▶ Please observe our specification according to data sheet 90220.
- ▶ We recommend brand name hydraulic fluids.
- ▶ Different oil types must not be mixed together as this may result in decomposition and deterioration of the lubricity.
- ▶ The fluid must be changed at certain intervals depending on the operating conditions. This involves cleaning residues from the fluid reservoir.

Drive

Electric motor + pump support + coupling + pump

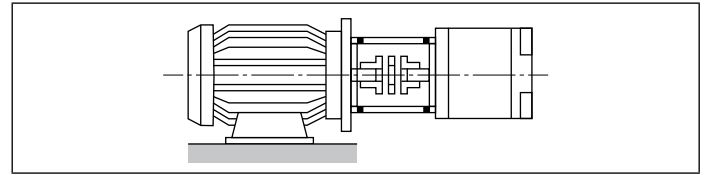

- ▶ No radial or axial forces permissible on the pump drive shaft!
- ▶ Motor and pump must be exactly aligned!
- ▶ Always use a coupling that is suitable for compensating shaft offsets!
- ▶ When installing the coupling, avoid axial forces, i. e. **do not hammer or press the coupling onto the shaft!** Use the female thread of the drive shaft!

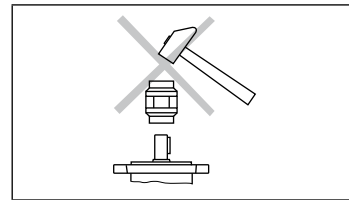

Installation positions

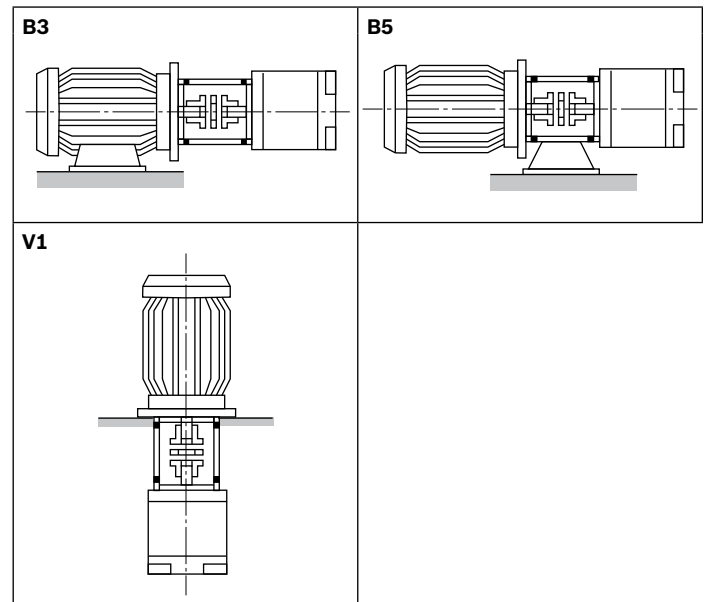

Commissioning instructions

Preparation

- ▶ Check whether the system is thoroughly and properly installed.
- ▶ Fill the hydraulic fluid only in through filters with the required minimum retention rate.
- ▶ Fill pump completely with fluid through suction and pressure line.
- ▶ Check the direction of rotation of the motor for compliance with the direction of rotation according to the pump type.

Air bleed

- ▶ Open the air bleeding port on the system by hand or change over to depressurized circulation in accordance with the instruction manual of the system. During air bleeding, the discharge of entrapped air must be ensured.
- ▶ To air bleed the pump, briefly switch the motor on and then switch it immediately off again (inching mode). Repeat this process until it is ensured that the pump has been completely air bled.
- ▶ Close the open air bleeding ports by hand.

Commissioning

- ▶ Once it is ensured that the pump has been completely air bled, switch on the motor. Let the pump run depressurized until the system is completely air bled. For air bleeding the system, observe the instruction manual for the system.
- ▶ Commission the system according to the instruction manual and let the pump run under load.
- ▶ After some time in operation, check the hydraulic fluid in the reservoir for bladders or the formation of foam on the surface.

Operation

- ▶ During operation, take note of changes in the noise emissions. A slight increase in the noise level is normal due to heating the operating medium. A significant increase in the noise level or brief, stochastic changes in the noise characteristics may indicate the aspiration of air. If suction lines are too short or fluid level not high enough air can also be primed in a swirl action.
- ▶ Changes in operating speeds, temperatures, increase in the noise level or power consumption indicate wear or damage to the system or pump.

Recommissioning

- ▶ Inspect the pump and system for leakage. Loss of oil indicates leakage below the hydraulic fluid level. An increased hydraulic fluid level in the reservoir indicates leakage above the hydraulic fluid level.
- ▶ If the pump is arranged above the hydraulic fluid level, the pump can drain due to leakages, for example due to a worn-out shaft seal ring. In this case, air bleeding is again required during recommissioning. Have the damage repaired.
- ▶ Air bleeding must again be performed following repair and maintenance work.
- ▶ Switch on the motor when the system is in flawless condition.

General

- ▶ Pumps delivered by us are tested for function and power. The warranty applies only to the delivered configuration.
- ▶ Repairs may only be performed by the manufacturer or his authorized dealers and subsidiaries. The entitlement to warranty cover will be rendered void if the product is incorrectly repaired, installed, commissioned or operated, or if it is used or handled improperly.
- ▶ Through opening, conversion or extension of the internal gear pump, the entitlement under warranty will be rendered void.

Notes

- ▶ Installation, maintenance and repair of the pump may only be carried out by authorized, trained and instructed personnel!
- ▶ The pump may only be operated at the permissible data (see pages 4).
- ▶ The pump may only be operated when in perfect condition!
- ▶ During all work on the pump, depressurize the system!
- ▶ Unauthorized conversions or changes that affect safety and function are not permissible!
- ▶ Mount safety devices (e.g., coupling protection) and do not remove any existing safety devices and equipment!
- ▶ Always ensure the proper fit of all mounting bolts! (Observe the specified tightening torques)
- ▶ The generally valid safety and accident prevention regulations must be observed!

Bosch Rexroth AG
Mobile Applications
Zum Eisengießer 1
97816 Lohr am Main, Germany
Tel. +49 9352 18-0
info.ma@boschrexroth.de
www.boschrexroth.com

© This document, as well as the data, specifications and other information set forth in it, are the exclusive property of Bosch Rexroth AG. It may not be reproduced or given to third parties without its consent. The data specified above only serve to describe the product. No statements concerning a certain condition or suitability for a certain application can be derived from our information. The information given does not release the user from the obligation of own judgment and verification. It must be remembered that our products are subject to a natural process of wear and aging.